

# ProRoll v2

Parallel roll alignment software

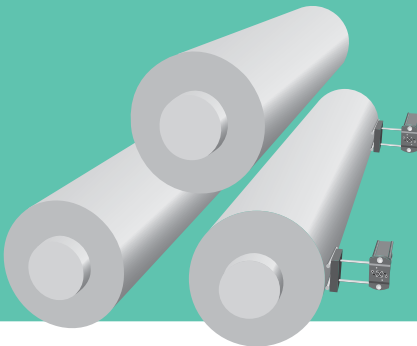

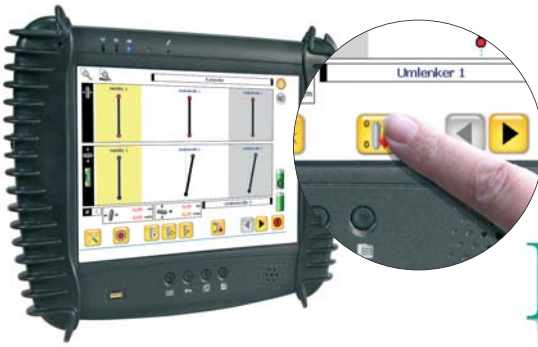

# ProRoll v2

## You have made a good choice ...

ProRoll v2, in combination with the display unit, is the optimum solution for the alignment of parallel rolls.

### The following functions and characteristics will convince you:

- Excellent user interface.
- Wireless sensor interface. No Cables.
- Automatic sensor detection.
- A new Reference Roll or line can be chosen during the measurement.
- Easy-to-use touchscreen, no keyboard needed.
- Reports and measured data can be stored on USB stick.
- 100 of rolls can be managed at the same time. Zoom in and out for clarity.
- High-performance display unit is robust and yet lightweight.

## Contents

Measurement setup .....	3
The software – first steps .....	5 ff
Tips and tricks .....	10
Register new sensors – license key .....	12
Description of program symbols .....	13
DU310 UMPC .....	14
Rotational laser T310 .....	16
The sensors	
R525 .....	17
R310 .....	17

## Measurement setup

Roll parallelism is one of the supreme disciplines within industrial surveying techniques. We combine 2 different sensor types and the Rotation laser to optimise this procedure.

The basic idea is that we use the rotating beam to buck in to the machine line. We use the IR Laser control offered by the R310 receivers to make this rapid. Then we use the standing beam which is always at right angles to the Rotating plane to pick up each roll position.

Choosing a reference.

1. Use an external reference line
2. Use one of the rolls
3. Make a new reference

### Setup:

#### Option 1

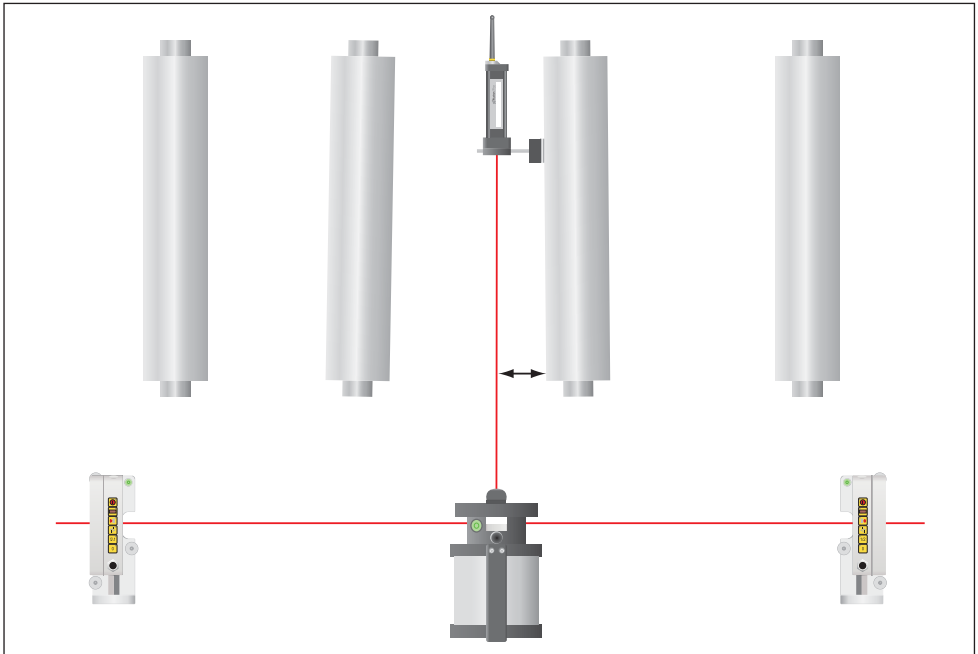

## Using an external reference line:

Pick up the line with the centering pin of the R310 floor adapter BG 830119. Use the sensor further away from the laser to buck in the beam. Use the offset screw on the laser mount to buck in the near side. That's it.

With a little practice you can buck in in 2 minutes.

Now turn off the rotation and use the standing beam to measure two points on the Roll. Repeat this procedure of each roll.

## Option 2

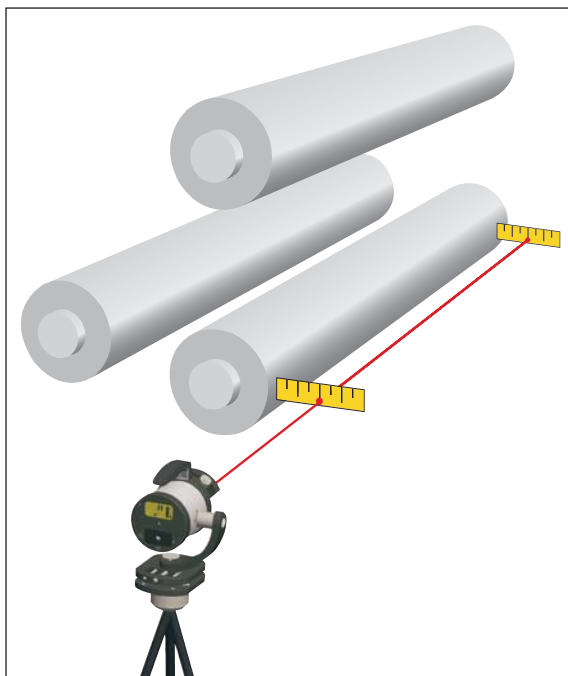

### Using a roll as reference:

Buck in the standing beam of the T310 laser with the remote control so that you measure nearly 0.0 at both ends.

Start rotation and place the R310 receivers left and right of the T310. Zero the R310.

They are now your reference.

## Option 3

You can redefine the reference with the ProRoll software anytime and as often as you wish. So in fact you can choose your reference freely.

## The software – first steps



Start the ProRoll v2 software via the desktop icon . The software automatically establishes a connection to the sensor.

*You will notice that in the upper right area, the Bluetooth symbol and the symbols for the receiver indicate an active connection.*

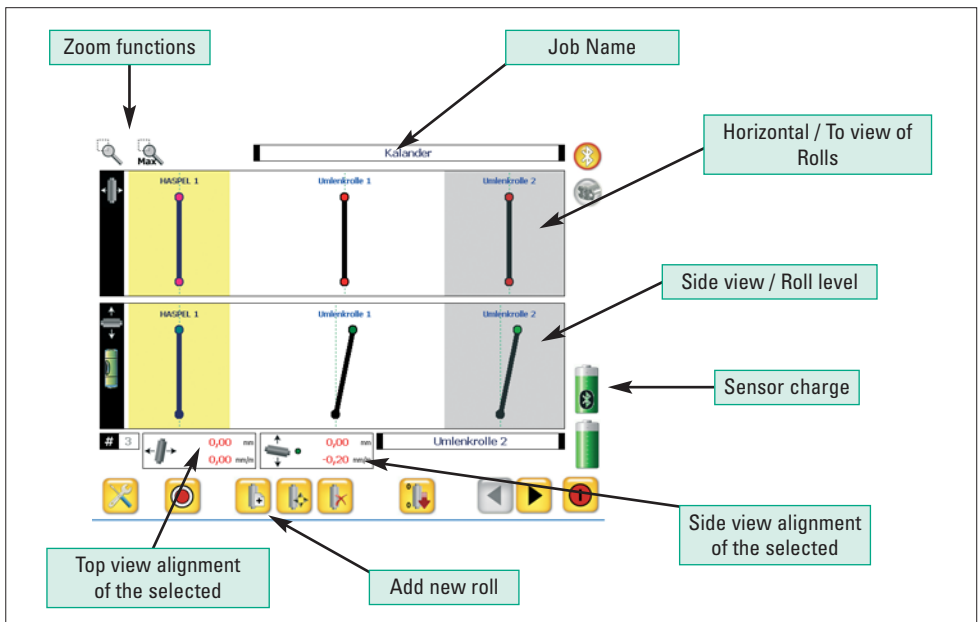

To measure press .

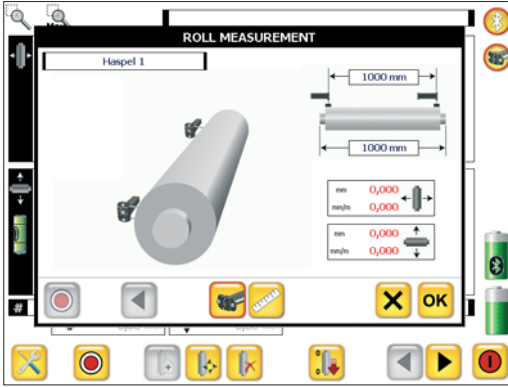

This is the measurement screen. Enter the roll length and the measurement length. (if they differ) Touch the sensor symbol where ever you want to measure first.

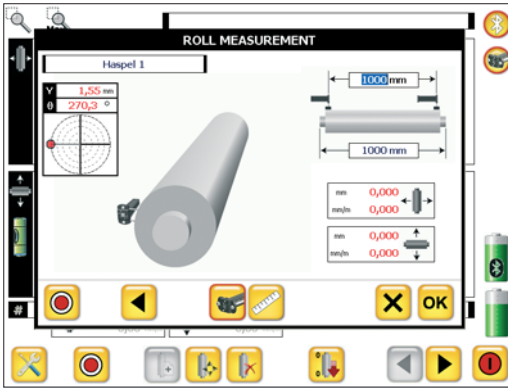

Position your sensor. The sensor has a inclinometer in it so it "knows" the angle. The current angle and measurement value is displayed top left. Press measure.

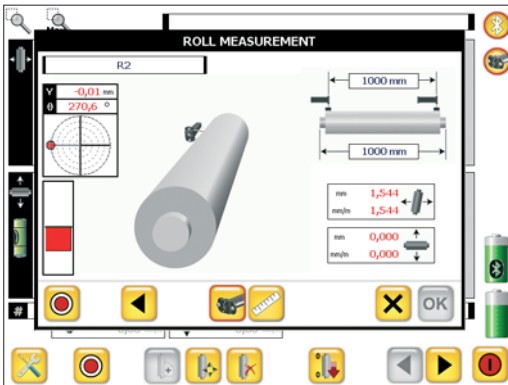

The sensor symbol will jump to the other end of the roll. Position your sensor there. The red bar meter will ensure that you are at the same angle as the first measurement. When you are positioned correctly press measure.

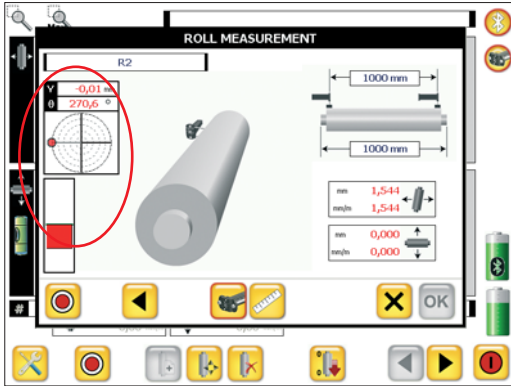

**Tip:** This bar graph idea means that you don't have to measure at exactly 3 or 9 o'clock.

Sometime that is not possible. You can go as far as 45 away from the ideal position.

This can be a big help.

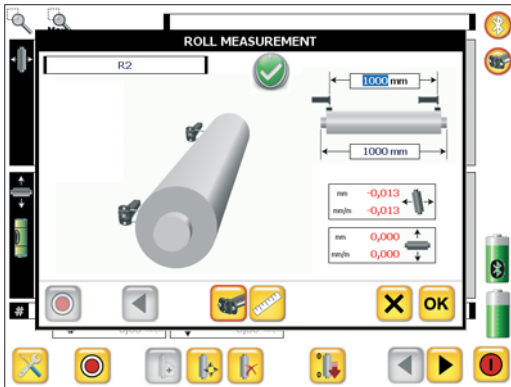

When you are finished the roll will get a green ok symbol ✓. The results are then visible in red.

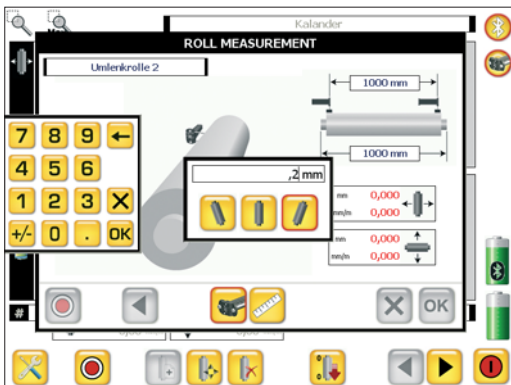



### Measuring the vertical plane

This can be done either with a water level or with T310 in a standing position.

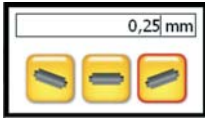
The result is entered as read in mm/m or mil/inch. Just touch the field to open the dialog.



This field is used to avoid confusion regarding + and -. Normally we use the convention that  means the ND side is too low and  means that the ND side is too high.

## Manual input

During first installation or major overhaul we often require a rapid and rough alignment. It is often helpful to do this with the laser beam and a tape measure. If we can mount from a crain with a accuracy of +/- 1mm in this way we will save a lot of time doing the fine adjust with the sensor later.

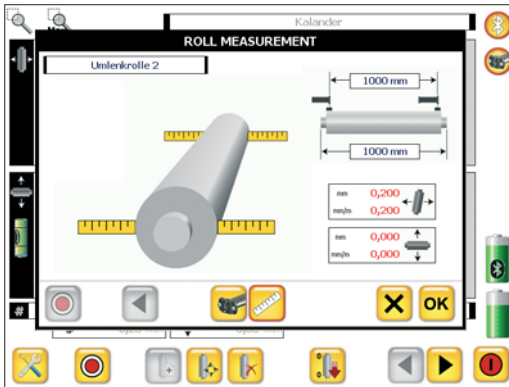



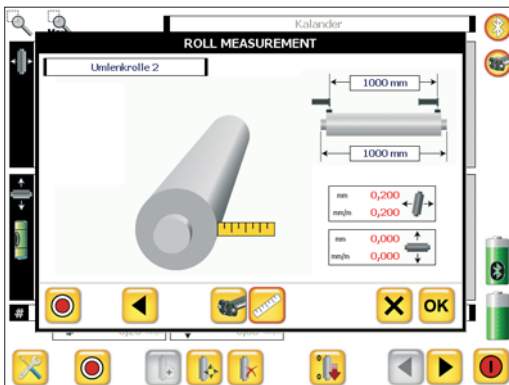

Choose the ruler button  rather than the sensor button.

Then just as before choose where you are measuring just by touching the appropriate ruler.

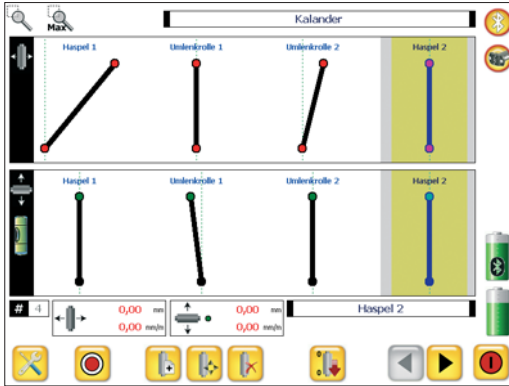



Just as before you will be prompted to the next position. Touch the remaining ruler and enter the measurement.

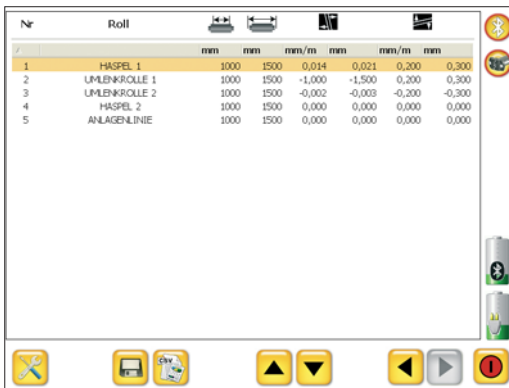

After you have measured a few rolls you will notice that each one can be seen in the overview screen. This is very helpful. Here we can zoom in  and out , slide back and forward  and choose a new reference .

Select a Roll by touching it then select a reference. You will notice that this roll is zeroed and all other rolls shift accordingly.



Go to the next page with  to see a table depiction of each roll. You can export this to Excel using the  button.

## Tips and tricks

The above method is not mysterious. Having understood the basics we can now combine this technique with a few traditional tips and tricks which can be very useful in real world applications.



Art.-No. BT 989050



Art.-No. BT 943510



Art.-No. BT 943501

### Setting floor reference points

Buck your laser in to the referenz roll. Place the R310 in the rotating beam and shift until it reads 0.0 mark the point with the Floor adapter pin. Use the BG 989050 to bore the hole. Place the floor point with the rawl plug.

Now shift the R310 again over the floorpoint to 0.0. Now mark the brass floor point with the Floor adapter pin. Perfect.

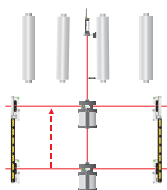

Art.-No. BG 830119

### Shifting center Lines

Often the centerline is in the middle of the machine and there for difficult to get at. It can be useful to shift it out a few meters to a more convenient place. The floor adapter has a slot for a holed tape measure. Thus you can conveniently shift the line out at the extremities of the machine. Make sure the reference is long w.r.t the roll length.

Talk to your Status Pro dealer about this.

The Ref Line is really a plane.

If you use the Autolevel function on the T310 the rotating beam makes a plane out of the reference line. This is often useful for aligning roll stacks or guides along the product path.

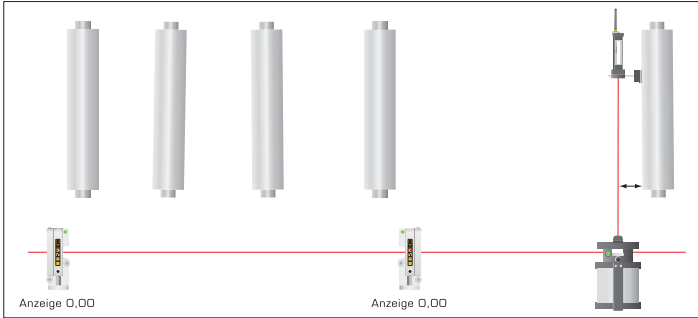

### Laser position.

You don't have to put the laser between the two reference receivers. Remember two points define a line. You can of course use this technique to extend your reference points in either direction. The resolution of the R310 at 0,02mm is good enough to keep the errors under control.

### Error Estimation:

Imagine our machine is 30 meters long and our rolls are 2 meters long. We place our reference points beyond the machine extremities 40m apart. An error of 0,1m at a reference point then is an angular error of  $0,1\text{mm}/40\text{m} = 0,0024\text{mm/m}$ . This causes a parallelity error of 0,005mm on our Roll.

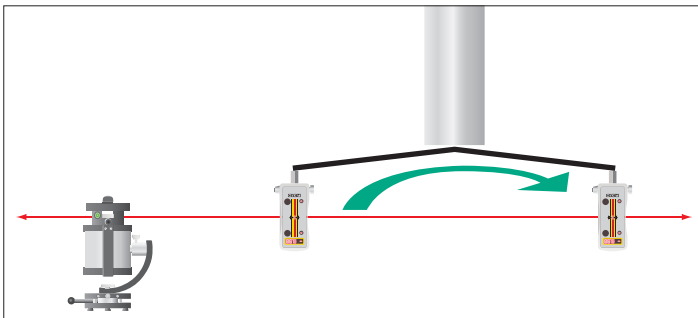

Using the reference plane of the T310 and a sensor arm. Fix the R310 to an arm. Attach the arm to the roll stub. Now rotate the roll. This is a very easy way to measure the vertical and horizontal angular deviation of the with respect to the reference plane. This method is used often for hidden rolls or wheels.

## Register new sensors – license key

When you order a measuring package with a display unit from Status Pro, all components are ready to use when you receive them. If you wish to use your own computer or add additional sensors later, they have to be registered in the software in order to enable communication.

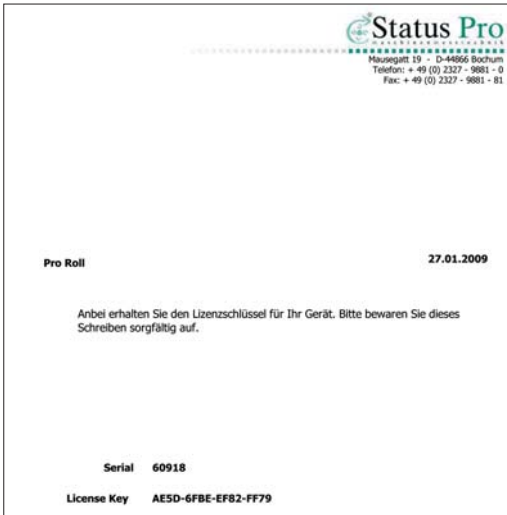





























With your sensors you receive a delivery note that includes a license key.

When you start ProRoll v2, the new sensor is found and the software prompts you to enter the license key.



Enter and confirm the license key that you received for the sensor. The unit is now ready for operation.

## Description of program symbols

- |   |   |
|---|---|
|  Record measuring point                       |  Set selected roll as Reference                                      |
|  Open / close settings                        |  Delete roll   |
|  Set pause for current measured value display |  Set new roll  |
|  Save a comment to the measuring              |  Position roll   |
|  Create new measuring data file               |  Define averaging time of the display                                |
|  Open measuring date file                     |  Define averaging time of the measuring pick-up                      |
|  Save results of measurement                  |  Define tolerance range  |
|  Previous / next page                         |  Bluetooth active / inactive   |
|  Search for sensors                           |  Sensors active / inactive   |
|  Delete measurement results                  |  No connection   |
|  Raw data                                   |  Charge condition of receiver / DU310                              |
|  Info                                       |  Enter sensor connection code (required only once for new sensors) |
|  Export results for reports                 |  End program   |
|  Save measurement                           |   |
|  Choose unit                                |   |







## DU310 UMPC



Art.-No. IT 200310

<b>Operating system</b>	Windows XP prof. (UMPC Edition), XP embedded or CE 5.0
<b>Processor</b>	AMD Geode LX800
<b>Memory</b>	512 MB - 1 GB RAM
<b>Mass storage</b>	512 MB - 8 GB Flash or 30 GB hard disk
<b>Display</b>	10.4" TFT, 1024x768, HiBrite
<b>Touchscreen</b>	Control with pen or finger
<b>Interfaces</b>	USB 2.0, CardBus PCMCIA Type II, CF-Card Slot, Bluetooth integrated, WLAN integrated, VGA
<b>Security</b>	Fingerprint reader, Intel WLAN Security
<b>Rechargeable battery</b>	Li-Ion 14 Wh internal, external extra battery 28 Wh replaceable or 74 Wh battery pack in carry bag
<b>Housing</b>	Magnesium/aluminum with rubber guard
<b>Operating environment</b>	Temperature 0-40 °C, relative humidity 0-90 % n.c.
<b>Dimensions &amp; weight</b>	ca. 210x261x18 mm, 0.93 kg incl. standard rechargeable battery
<b>Special features</b>	Front is splash water proof, shock proof from as high as 1.2 m (with rubber guard), 5 configurable keys, up to 4 hours of operation; Optional: multi-language, daylight display

## Accessories for DU310 UMPC

Illustration	Art. no.	Name
	IT 200202	<b>Replacement control pen</b> Quantity of 3 / package
	IT 200205	<b>Rubber guard handle</b> for holding the UMPC with one hand; is fastened on back on rubber guard
	IT 200206	<b>Carrying strap for rubber guard handle</b> is fastened on back on rubber guard
	IT 200207	<b>External extra battery Li-Ion 28W</b> can be replaced during operation
	IT 200208	<b>1-compartment charging station for external battery</b>
	IT 200209	<b>Car DC-DC converter 12V / 24V</b> for connecting to docking station / car mounts or directly to the unit
	IT 200211	<b>External expansion battery pack</b> Li-ion 73Wh, charge level display



Art. no. BG 830200/1

## Rotational laser T310

The T310 leveling laser makes even difficult measuring tasks easy! A laser transmitter transmits the signal and a detector measures the beam position. Done!

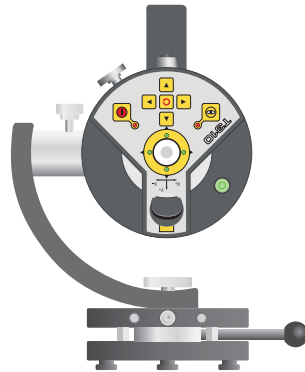

### Control of the T310

The control keys control various functions. In addition, LEDs function as displays.

1. IR-receiver with folding mirror
2. Levelling status -LED for Y-axis (or Z-axis in case of laying arrangement)  
Green 1x: Levelling < 0.04 mm/m;  
2x: Levelling < 0.025 mm/m;  
Red LED: Actuator motor working
3. Levelling status LED for X-axis  
Green 1x: Levelling < 0.04 mm/m;  
2x: Levelling < 0.025 mm/m;  
Red LED: Actuator motor working
4. Power status LED on / off
5. Power key on/off
6. Laser rotation on/off
7. Key cross for setting the laser level 5(+)/6(-)  
As well as 3(+)/4(-)
8. Self-levelling on/off
9. Levelling status LED on/off
10. Level for rough levelling of the appliance

## The sensors

### R525

**R525** is a battery-operated, wireless high-precision laser receiver for perfect straightness measurements of the chain guideways. This makes it possible to measure and document a 10-meter guideway in centimeter sections in five minutes.

24x24mm PSD,  
ohne Optik



Art.-No. SP-R525-P

<b>Measuring range</b>	20x20mm
<b>Resolution</b>	1µm in X & Y
<b>Accuracy</b>	+/- 2µm
<b>Laser sensitivity</b>	650nm / modulated
<b>Wireless</b>	Bluetooth class 1a (range: 30m)
<b>Interface</b>	Rs232 / Bluetooth
<b>Power supply</b>	12V rechargeable battery
<b>Operation with battery</b>	8 hours
<b>Charging time</b>	2 hours – 90%
<b>Protection class</b>	IP 65

### R310

The R310 measures the position of the rotating laser beam, as a dial gauge from the work-piece for reference. The beam forms an entire reference plane and not only a line like a wire. The R310 is wireless and has a range of up to 80 meters.



Art.-No. BG 830100

<b>Measuring range</b>	80mm
<b>Resolution</b>	0.01mm
<b>Accuracy</b>	+/- 0.02 + 0.3% linearity
<b>IR control</b>	Range: 50m
<b>Interface</b>	Rs232 / Bluetooth (optional)
<b>Power supply</b>	(rechargeable) battery 6x AA
<b>Temperature range</b>	0-50°C



Status Pro Maschinenmesstechnik GmbH  
Mausegatt 19  
D-44866 Bochum  
Phone: + 49 (0) 2327 - 9881 - 0  
Fax: + 49 (0) 2327 - 9881 - 81  
[www.statuspro.com](http://www.statuspro.com)  
[info@statuspro.com](mailto:info@statuspro.com)

BA 1007E 02/09 · Design / DTP: Seichter & Steffens Grafikdesign, Dortmund

Copyright 2009 Status Pro Maschinenmesstechnik GmbH. This user guide or parts thereof may not be copied or otherwise reproduced without explicit written from the management of Status Pro GmbH. The technical details are subject to change without notification. We would appreciate being informed of any errors in this manual.